



## Bid Notice Abstract

### Request for Quotation (RFQ)

**Reference Number** 7873006  
**Procuring Entity** BUREAU OF SOILS AND WATER MANAGEMENT  
**Title** Repair and restoration of BSWM Convention Hall gutter and downspout  
**Area of Delivery** Metro Manila

<b>Solicitation Number:</b> BSWM PR 2021-06-1148	<b>Status</b>	<b>Closed</b>
<b>Trade Agreement:</b> Implementing Rules and Regulations	<b>Associated Components</b>	4
<b>Procurement Mode:</b> Negotiated Procurement - Small Value Procurement (Sec. 53.9)	<b>Bid Supplements</b>	0
<b>Classification:</b> Civil Works	<b>Document Request List</b>	2
<b>Category:</b> General Repair and Maintenance Services	<b>Date Published</b>	27/07/2021
<b>Approved Budget for the Contract:</b> PHP 884,591.50	<b>Last Updated / Time</b>	27/07/2021 00:00 AM
<b>Delivery Period:</b> 60 Day/s	<b>Closing Date / Time</b>	02/08/2021 11:00 AM
<b>Client Agency:</b>		
<b>Contact Person:</b> Denise Araullo Solano Head, Procurement Management Section SRDC Bldg., Elliptical Road corner Visayas Avenue, Diliman Quezon City Metro Manila Philippines 1101 63-2-83528012 63-2-83528012 denise.solano@bswm.da.gov.ph		

#### Description

Repair and restoration of BSWM Convention Hall gutter and downspout inclusive of labor and materials.

Location: BSWM, Quezon City.

Program Duration: 60 days upon receipt of Notice to Proceed.

Specifications:

1. See attached:
  - a. General Conditions of Contract and Special Conditions of Contract
  - b. Scope of Work
  - c. Cost Estimate
  - d. Drawings
2. Site Inspection is required. Coordinate with End-user (Building and Grounds Administration) through telephone number 89230438.
3. The following documents shall be submitted in ONE ENVELOPE not later than August 2, 2021; 11:00AM:
  - a. Certificate of Site Inspection signed by Head of BGA.

- b. Certificate signed by Authorized Representative that IATF protocols and guidelines on measures against COVID 19 will be complied and implemented during contract implementation.
- c. Proposed Timeline (Program of Works)
- d. Detailed Bill of Quantities (TOTAL BID PRICE in BOLD FONT)
- e. Name of Supervisor during Contract Implementation
- f. Documentary Requirements:
  - i. PhilGEPS Certificate Number
  - ii. Mayor's Permit
  - iii. Latest ITR
  - iv. Notarized Revised Omnibus Sworn Statement
  - v. PCAB License appropriate to required works

**Other Information**

**NOTE:**

The following shall be submitted 10 calendar days upon receipt of Notice of Award

1. Performance Security
2. Program of Works
3. Name of Personnel
4. Warranty Security will be required upon completion of contract. Three months

Quotation(s)/Proposal(s) shall be submitted to the Procurement Management Section, Bureau of Soils and Water Management, Elliptical Road cor Visayas Ave., Diliman, Quezon City.

**Created by** Denise Araullo Solano

**Date Created** 26/07/2021

The PhilGEPS team is not responsible for any typographical errors or misinformation presented in the system. PhilGEPS only displays information provided for by its clients, and any queries regarding the postings should be directed to the contact person/s of the concerned party.

## ***Section IV. General Conditions of Contract***

### **Notes on the General Conditions of Contract**

The General Conditions of Contract (GCC) in this Section, read in conjunction with the Special Conditions of Contract in Section V and other documents listed therein, should be a complete document expressing all the rights and obligations of the parties.

Matters governing performance of the Contractor, payments under the contract, or matters affecting the risks, rights, and obligations of the parties under the contract are included in the GCC and Special Conditions of Contract.

Any complementary information, which may be needed, shall be introduced only through the Special Conditions of Contract.

## **1. Scope of Contract**

This Contract shall include all such items, although not specifically mentioned, that can be reasonably inferred as being required for its completion as if such items were expressly mentioned herein. All the provisions of RA No. 9184 and its 2016 revised IRR, including the Generic Procurement Manual, and associated issuances, constitute the primary source for the terms and conditions of the Contract, and thus, applicable in contract implementation. Herein clauses shall serve as the secondary source for the terms and conditions of the Contract.

This is without prejudice to Sections 74.1 and 74.2 of the 2016 revised IRR of RA No. 9184 allowing the GPPB to amend the IRR, which shall be applied to all procurement activities, the advertisement, posting, or invitation of which were issued after the effectivity of the said amendment.

## **2. Sectional Completion of Works**

If sectional completion is specified in the **Special Conditions of Contract (SCC)**, references in the Conditions of Contract to the Works, the Completion Date, and the Intended Completion Date shall apply to any Section of the Works (other than references to the Completion Date and Intended Completion Date for the whole of the Works).

## **3. Possession of Site**

3.1 The Procuring Entity shall give possession of all or parts of the Site to the Contractor based on the schedule of delivery indicated in the **SCC**, which corresponds to the execution of the Works. If the Contractor suffers delay or incurs cost from failure on the part of the Procuring Entity to give possession in accordance with the terms of this clause, the Procuring Entity's Representative shall give the Contractor a Contract Time Extension and certify such sum as fair to cover the cost incurred, which sum shall be paid by Procuring Entity.

3.2 If possession of a portion is not given by the above date, the Procuring Entity will be deemed to have delayed the start of the relevant activities. The resulting adjustments in contract time to address such delay may be addressed through contract extension provided under Annex "E" of the 2016 revised IRR of RA No. 9184.

## **4. The Contractor's Obligations**

The Contractor shall employ the key personnel named in the Schedule of Key Personnel to carry out the supervision of the Works.

The Procuring Entity will approve any proposed replacement of key personnel only if their relevant qualifications and abilities are equal to or better than those of the personnel listed in the Schedule.

## **5. Performance Security**

- 5.1. Within ten (10) calendar days from receipt of the Notice of Award from the Procuring Entity but in no case later than the signing of the contract by both parties, the successful Bidder shall furnish the performance security in any of the forms prescribed in Section 39 of the 2016 revised IRR.
- 5.2. The Contractor, by entering into the Contract with the Procuring Entity, acknowledges the right of the Procuring Entity to institute action pursuant to RA No. 3688 against any subcontractor be they an individual, firm, partnership, corporation, or association supplying the Contractor with labor, materials and/or equipment for the performance of this Contract.

## **6. Site Investigation Reports**

The Contractor, in preparing the Bid, shall rely on any Site Investigation Reports referred to in the SCC supplemented by any information obtained by the Contractor.

## **7. Warranty**

- 7.1. In case the Contractor fails to undertake the repair works under Section 62.2.2 of the 2016 revised IRR, the Procuring Entity shall forfeit its performance security, subject its property(ies) to attachment or garnishment proceedings, and perpetually disqualify it from participating in any public bidding. All payables of the GOP in his favor shall be offset to recover the costs.
- 7.2. The warranty against Structural Defects/Failures, except that occasioned-on force majeure, shall cover the period from the date of issuance of the Certificate of Final Acceptance by the Procuring Entity. Specific duration of the warranty is found in the SCC.

## **8. Liability of the Contractor**

Subject to additional provisions, if any, set forth in the SCC, the Contractor's liability under this Contract shall be as provided by the laws of the Republic of the Philippines.

If the Contractor is a joint venture, all partners to the joint venture shall be jointly and severally liable to the Procuring Entity.

## **9. Termination for Other Causes**

Contract termination shall be initiated in case it is determined *prima facie* by the Procuring Entity that the Contractor has engaged, before, or during the implementation of the contract, in unlawful deeds and behaviors relative to contract acquisition and implementation, such as, but not limited to corrupt, fraudulent, collusive, coercive, and obstructive practices.

## **10. Dayworks**

Subject to the guidelines on Variation Order in Annex “E” of the 2016 revised IRR of RA No. 9184, and if applicable as indicated in the **SCC**, the Dayworks rates in the Contractor’s Bid shall be used for small additional amounts of work only when the Procuring Entity’s Representative has given written instructions in advance for additional work to be paid for in that way.

## **11. Program of Work**

11.1. The Contractor shall submit to the Procuring Entity’s Representative for approval the said Program of Work showing the general methods, arrangements, order, and timing for all the activities in the Works. The submissions of the Program of Work are indicated in the **SCC**.

11.2. The Contractor shall submit to the Procuring Entity’s Representative for approval an updated Program of Work at intervals no longer than the period stated in the **SCC**. If the Contractor does not submit an updated Program of Work within this period, the Procuring Entity’s Representative may withhold the amount stated in the **SCC** from the next payment certificate and continue to withhold this amount until the next payment after the date on which the overdue Program of Work has been submitted.

## **12. Instructions, Inspections and Audits**

The Contractor shall permit the GOP or the Procuring Entity to inspect the Contractor’s accounts and records relating to the performance of the Contractor and to have them audited by auditors of the GOP or the Procuring Entity, as may be required.

## **13. Advance Payment**

The Procuring Entity shall, upon a written request of the Contractor which shall be submitted as a Contract document, make an advance payment to the Contractor in an amount not exceeding fifteen percent (15%) of the total contract price, to be made in lump sum, or at the most two installments according to a schedule specified in the **SCC**, subject to the requirements in Annex “E” of the 2016 revised IRR of RA No. 9184.

## **14. Progress Payments**

The Contractor may submit a request for payment for Work accomplished. Such requests for payment shall be verified and certified by the Procuring Entity’s Representative/Project Engineer. Except as otherwise stipulated in the **SCC**, materials and equipment delivered on the site but not completely put in place shall not be included for payment.

## **15. Operating and Maintenance Manuals**

- 15.1. If required, the Contractor will provide “as built” Drawings and/or operating and maintenance manuals as specified in the **SCC**.
- 15.2. If the Contractor does not provide the Drawings and/or manuals by the dates stated above, or they do not receive the Procuring Entity’s Representative’s approval, the Procuring Entity’s Representative may withhold the amount stated in the **SCC** from payments due to the Contractor.

## ***Section V. Special Conditions of Contract***

### **Notes on the Special Conditions of Contract**

The clauses in this Section are intended to assist the Procuring Entity in providing contract-specific information in relation to corresponding clauses in the GCC found in Section IV.

The Special Conditions of Contract (SCC) complement the GCC, specifying contractual requirements linked to the special circumstances of the Procuring Entity, the Procuring Entity's country, the sector, and the Works procured. In preparing this Section, the following aspects should be checked:

- a. Information that complements provisions of the GCC must be incorporated.
- b. Amendments and/or supplements to provisions of the GCC as necessitated by the circumstances of the specific purchase, must also be incorporated.

However, no special condition which defeats or negates the general intent and purpose of the provisions of the GCC should be incorporated herein.



# Special Conditions of Contract

GCC Clause	
2	<i>Not Applicable</i>
4.1	<i>[Specify the schedule of delivery of the possession of the site to the Contractor, whether full or in part.]</i>
6	The site investigation reports are: <i>Actual site inspection</i>
7.2	<i>Warranty of 6 months from date of completion.</i>
10	No dayworks are applicable to the contract.
11.1	The Contractor shall submit the Program of Work to the Procuring Entity's Representative within <i>10 calendar</i> days of delivery of the Notice of Award.
11.2	The amount to be withheld for late submission of an updated Program of Work is <i>[insert amount]</i> .
13	The amount of the advance payment is <i>shall not exceed 15% of the total contract price.</i>
14	<i>[If allowed by the Procuring Entity, state:]</i> Materials and equipment delivered on the site but not completely put in place shall be included for payment.
15.1	The date by which operating and maintenance manuals are required is <i>[date]</i> .  The date by which "as built" drawings are required is <i>[date]</i> .
15.2	The amount to be withheld for failing to produce "as built" drawings and/or operating and maintenance manuals by the date required is <i>[amount in local currency]</i> .

GUTTER - FOR RESTORATION

PROMSION FOR DROP OUTLET

INSTALLATION OF NEW PIPE SUPPORT SPACED @ 1.00 MTS.

REPLACEMENT OF DELAPIDATED PIPE FITTINGS

PATCH-UP WORKS FOR EXISTING DOWN PIPE.

INSTALLATION OF NEW PIPE SUPPORT SPACED @ 1.00 MTS.

REPLACEMENT OF DELAPIDATED PIPE FITTINGS

INSTALLATION OF NEW PIPE SUPPORT SPACED @ 1.00 MTS.

INSTALLATION OF NEW PIPE SUPPORT SPACED @ 1.00 MTS.

# DETAILS OF GUTTER AND DOWNPIPE REPAIR

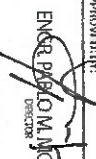
DESIGNED BY:  ENGINEER DATE: 07.24.2011	PROJECT TITLE: <b>PROPOSED GUTTER AND DOWNPIPE REPAIR OF BUREAU OF SOILS &amp; WATER MANAGEMENT</b> VISAYAS (M.A.R.C., BUREAU, DUF-ZON, CITY)	SUBMITTED BY: <b>BUREAU OF SOILS &amp; WATER MANAGEMENT</b> DATE: 07.24.2011	APPROVED BY:  ENGR. P. O. M. MONTALLA DIRECTOR	SHEET NO. IN SET OF GUTTER AND DOWNPIPE REPAIR <b>A-1</b> TOTAL NO. OF SHEETS: <b>3</b>
--	---	--	--	---

GUTTER - FOR RESTORATION

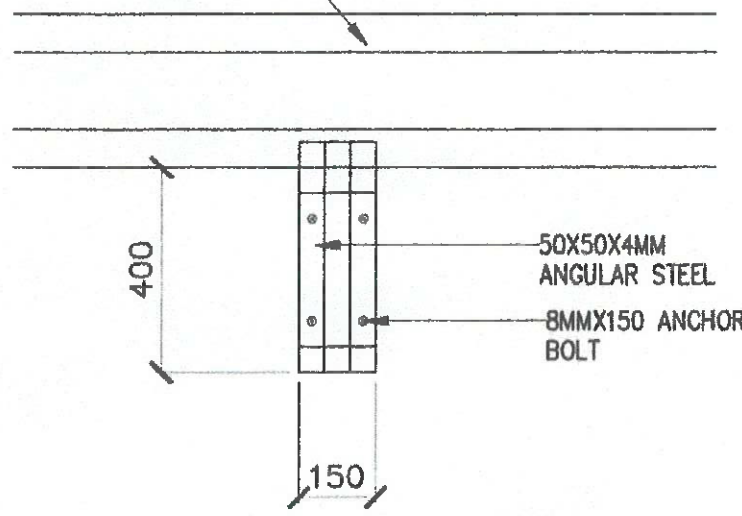

FRONT ELEVATION

GUTTER - FOR RESTORATION

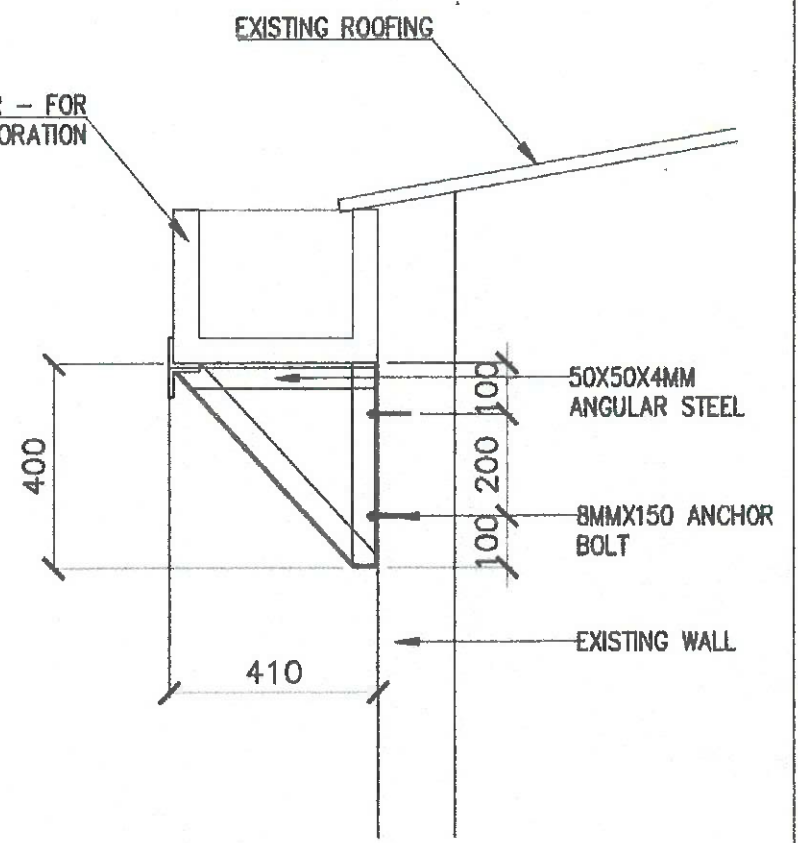

SIDE ELEVATION

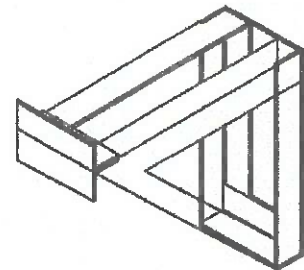

ISOMETRIC DRAWING OF BRACKET

BRACKET DETAILS

DESIGNED BY: ENGR. PABLO M. MONTALLA	PROJECT TITLE: PROPOSED GUTTER AND DOWNPIPE REPAIR OF BUREAU OF SOILS & WATER MANAGEMENT VISAYAS AVENUE, DELMAN, QUEZON CITY	SUBMITTED BY: BUREAU OF SOILS & WATER MANAGEMENT	APPROVED BY: ENGR. PABLO M. MONTALLA DIRECTOR	SHEET CONTAINS: BRACKET DETAIL	SHEET NO.: A-2 2 OF 3
PRJ: 010001	TEL: 348-007-200-000				
PTF: 320047	DATE: 01.31.2021				
CADD BY: A.R.V.	DATE: 07.14.2021				

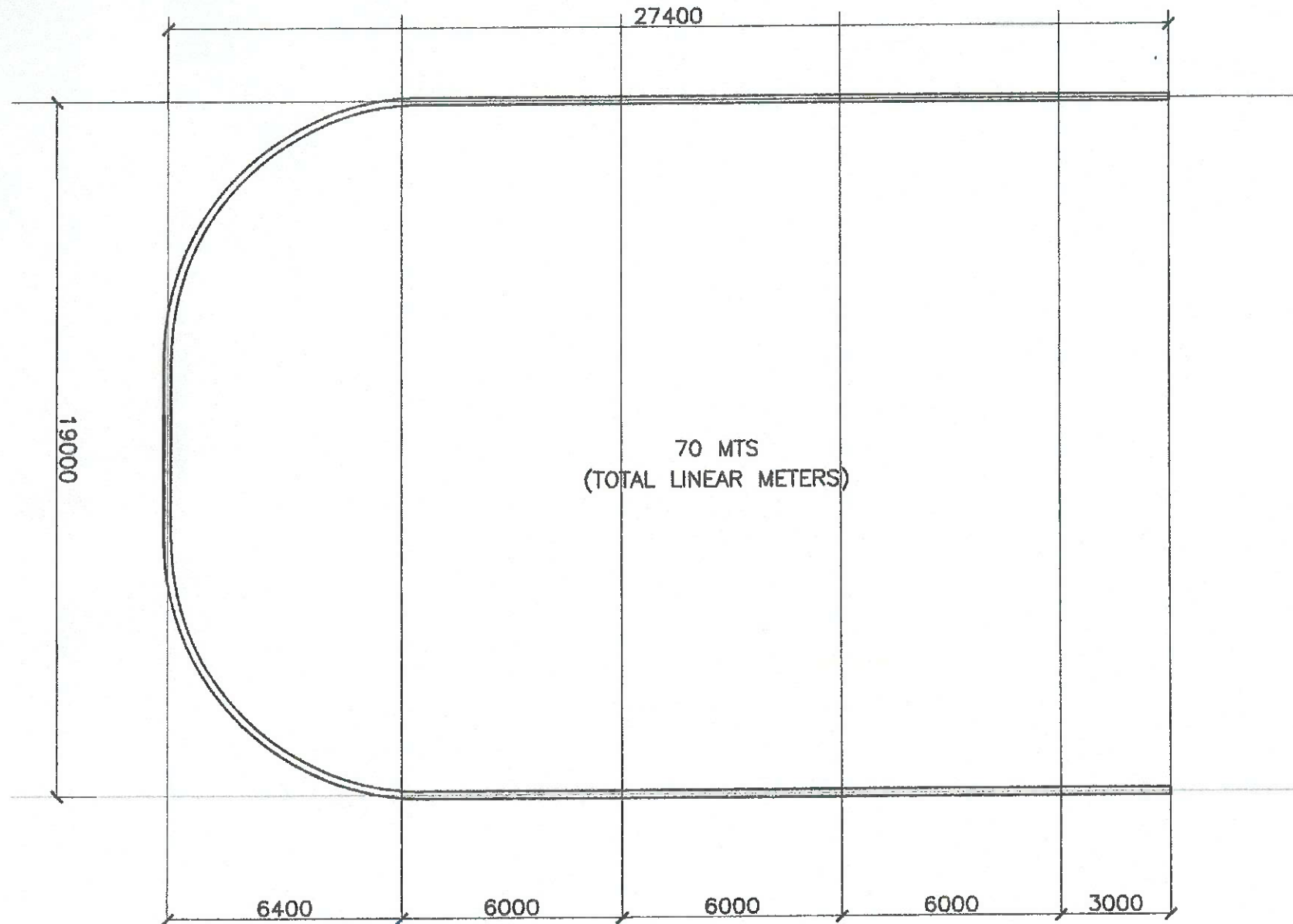

# GUTTER LAYOUT

DESIGNED BY: ENGR. PABLO M. MONTALLA DIRECTOR	PROJECT TITLE: PROPOSED GUTTER AND DOWNPIPE REPAIR OF BUREAU OF SOILS & WATER MANAGEMENT VISAYAS AVENUE, DR. IMAN, QUEZON CITY	SUBMITTED BY: BUREAU OF SOILS & WATER MANAGEMENT O. W. MONTALLA	APPROVED BY: ENGR. PABLO M. MONTALLA DIRECTOR	SHEET CONTENTS: GUTTER DETAIL	SHEET NO.: A-2 PAGE NO. OF TOTAL NO. OF PAGE: 2 OF 3
DATE: 07-14-2021	DATE: 07-14-2021				